

16 inch lid

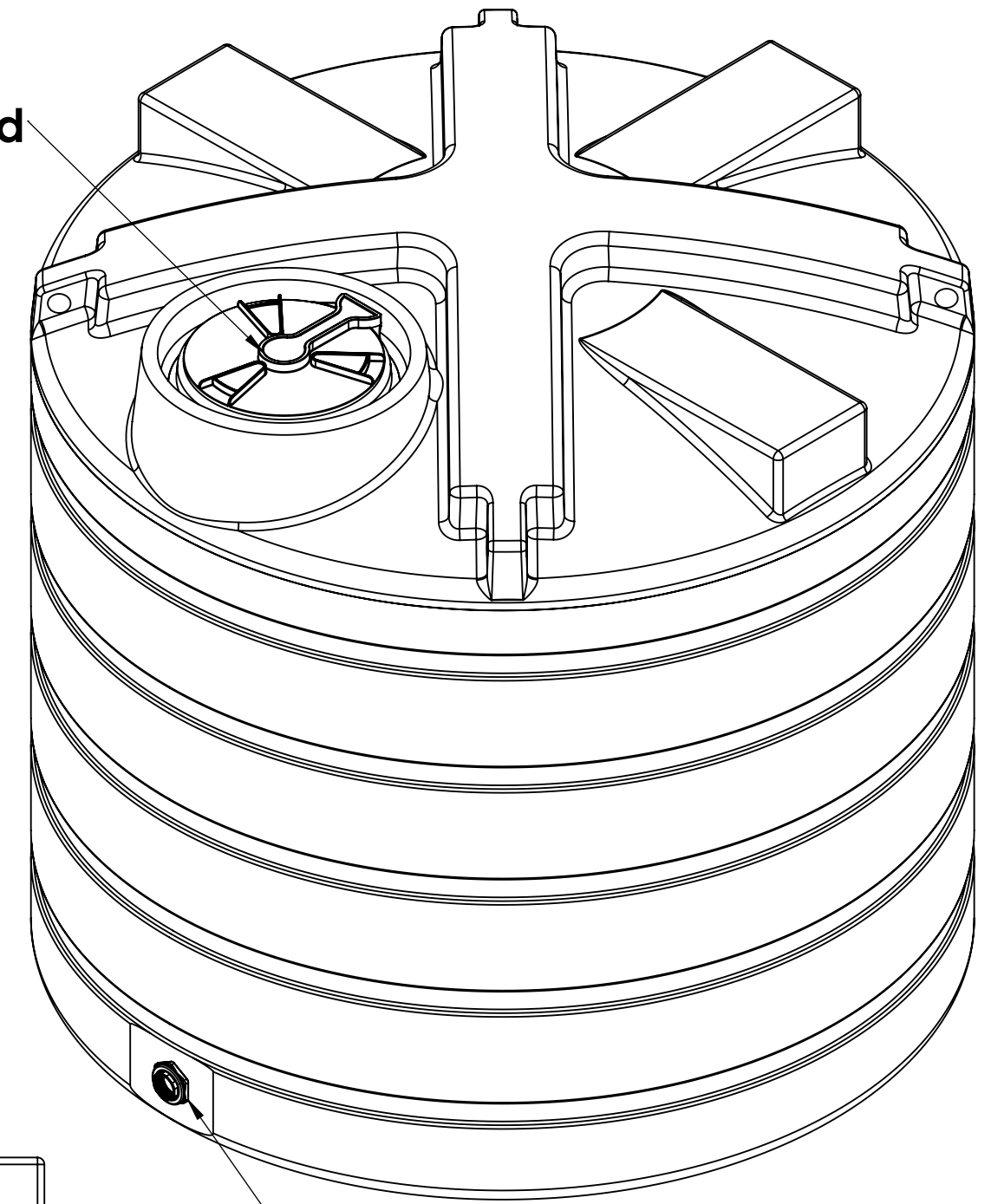

2 inch threaded fitting

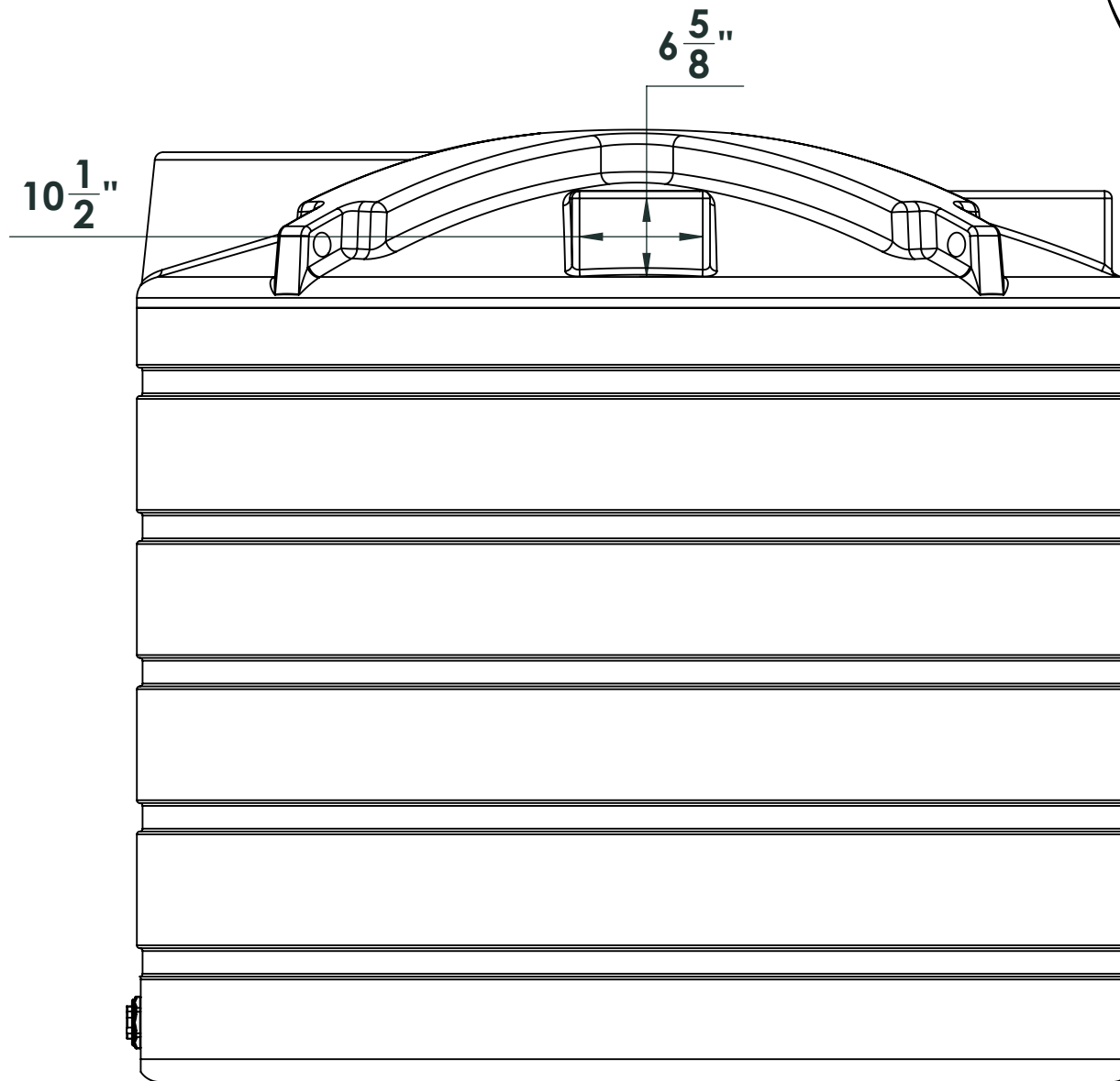
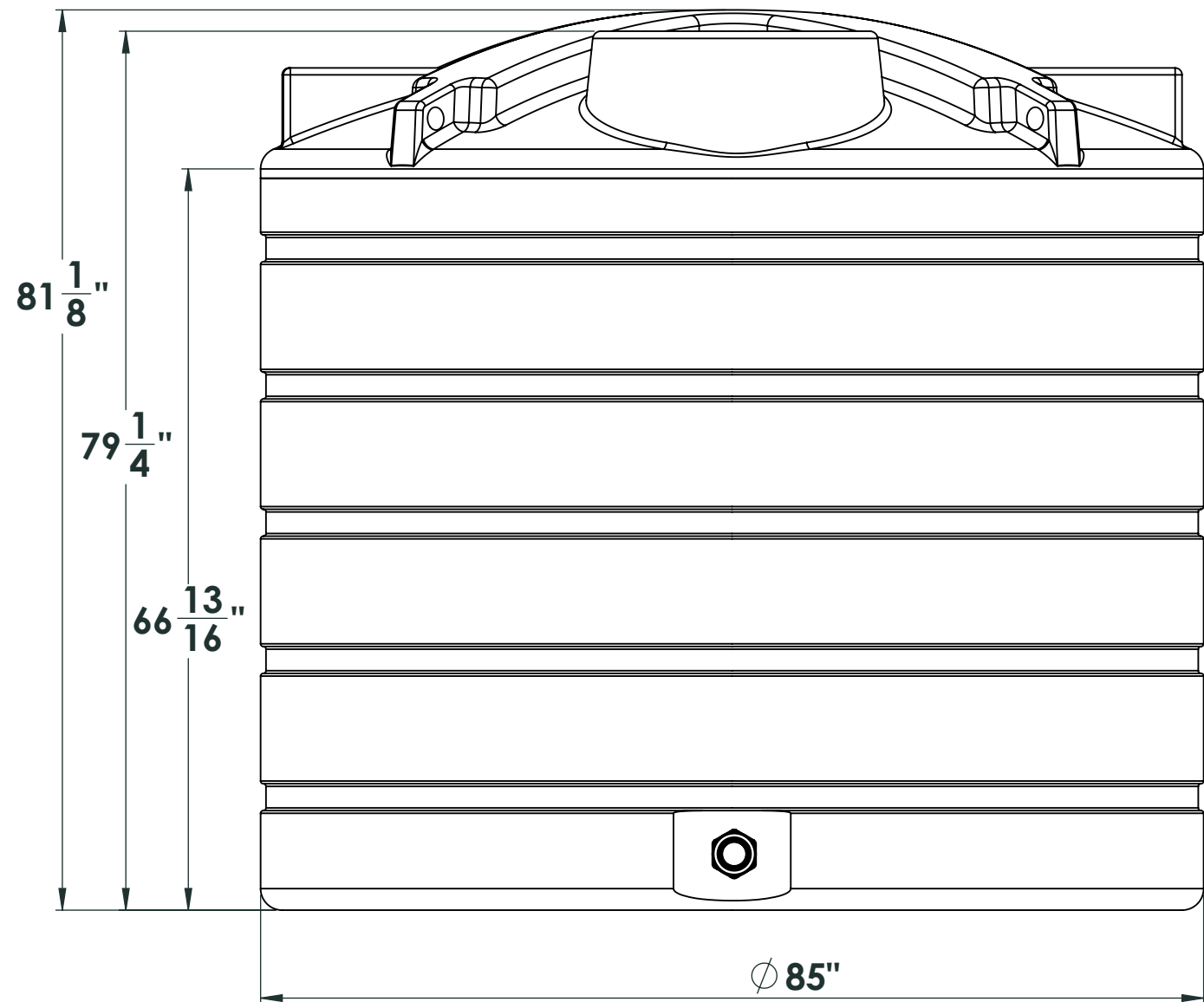

**NOTE: Allow +/- 1.5% Shrinkage**

**PROPRIETARY AND CONFIDENTIAL**  
 THE INFORMATION CONTAINED IN THIS DRAWING IS THE SOLE PROPERTY OF ENDURAPLAS LLC. ANY REPRODUCTION IN PART OR AS A WHOLE WITHOUT THE WRITTEN PERMISSION OF ENDURAPLAS LLC IS PROHIBITED.

UNLESS OTHERWISE SPECIFIED:		NAME	DATE	ENDURAPLAS LLC
DIMENSIONS ARE IN INCHES		DRAWN	DNS	
TOLERANCES:		CHECKED		TITLE:
FRACTIONAL ±		ENG APPR.		THV01550
ANGULAR: MACH ± BEND ±		MFG APPR.		SIZE DWG. NO.
TWO PLACE DECIMAL ±		Q.A.		REV
THREE PLACE DECIMAL ±		COMMENTS:		1
INTERPRET GEOMETRIC TOLERANCING PER:	MATERIAL			SCALE: 1:50 WEIGHT:
FINISH	DO NOT SCALE DRAWING			SHEET 1 OF 1
NEXT ASSY	USED ON			
APPLICATION				